

1 Water Seal

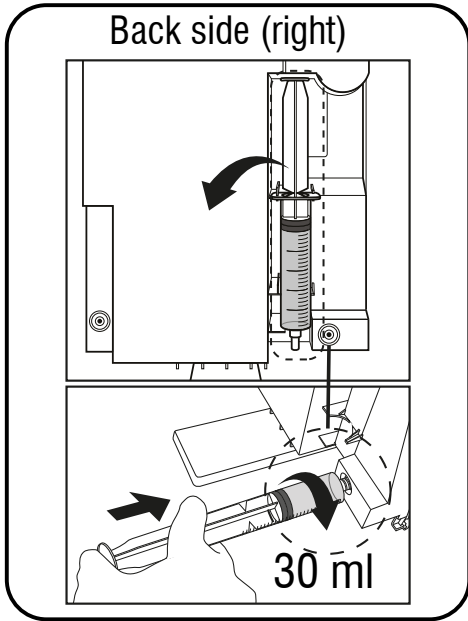

2 Or Fill Sterile Water into the Suction Port

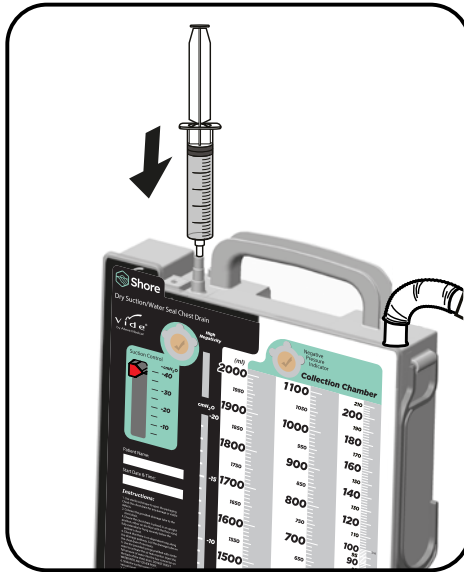

3 Suction Control Regulator

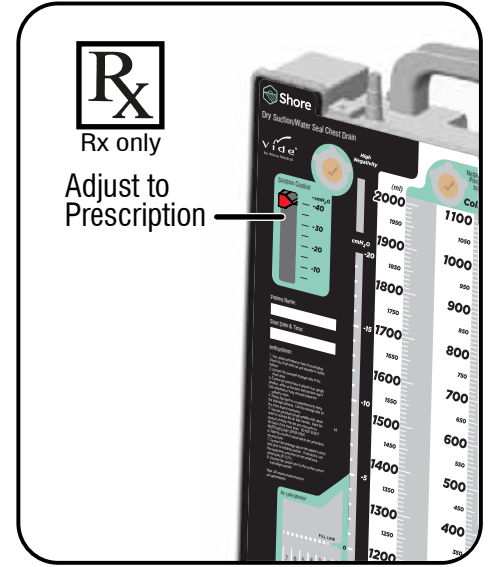

4 Patient Tube

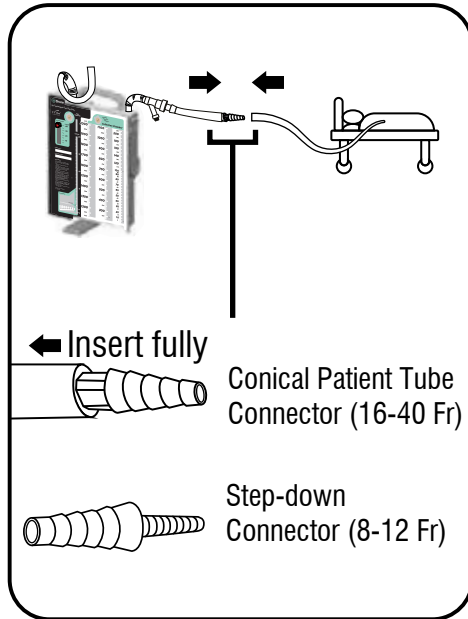

5 Suction Source

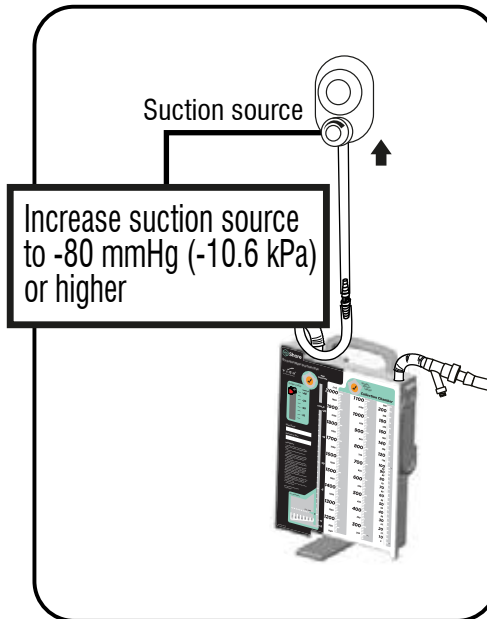

6a Needle-less Sampling

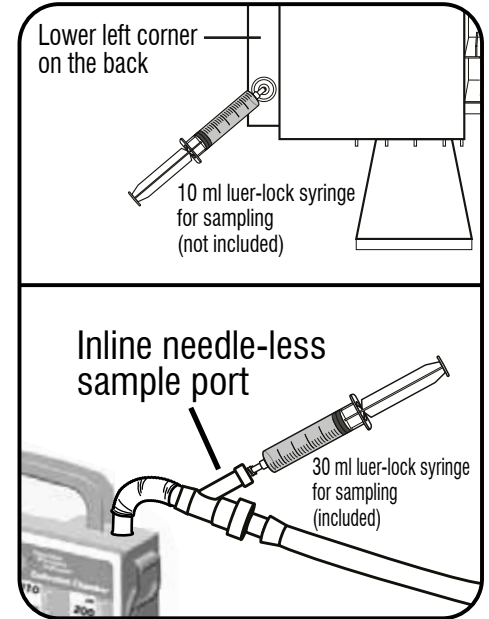

6b Sampling with Needle

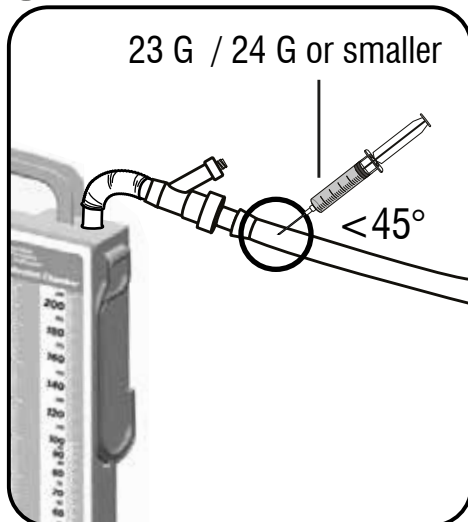

7 Disposal

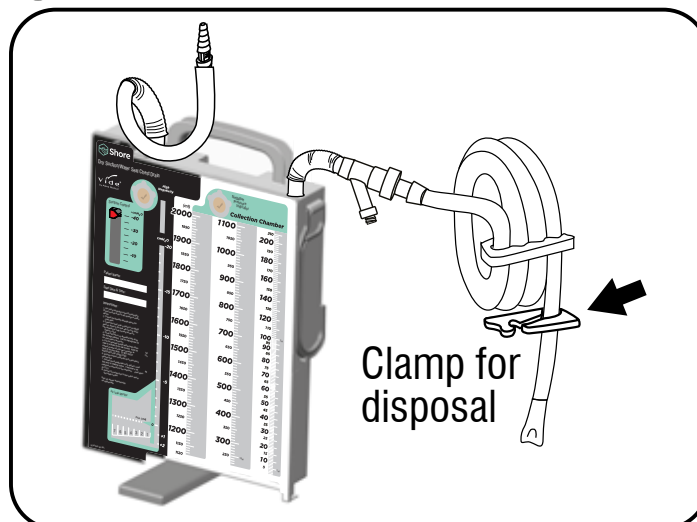

See Video